

CIV RANGE

The CIV range of in-line centrifugal fan unit is available in 6 standard sizes by using different case / impeller combinations.

These units have been designed to operate in very confined areas such as those above fume cupboards.

All units are fitted with the CMV forward curved impeller directly driven by a TEFC IP55 motor as standard which is mounted out of the airstream inside a ventilated chamber, an external terminal box is provided for ease of installation.

These units are available in Polypropylene as standard with other materials are also available upon request.

Please note that these fan units are not suitable for zoned areas.

CIV Range - Series III Performance Curves

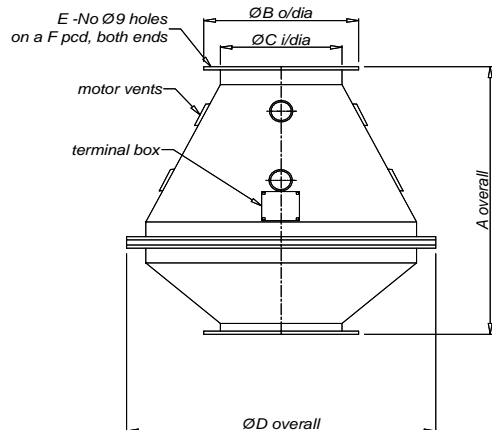
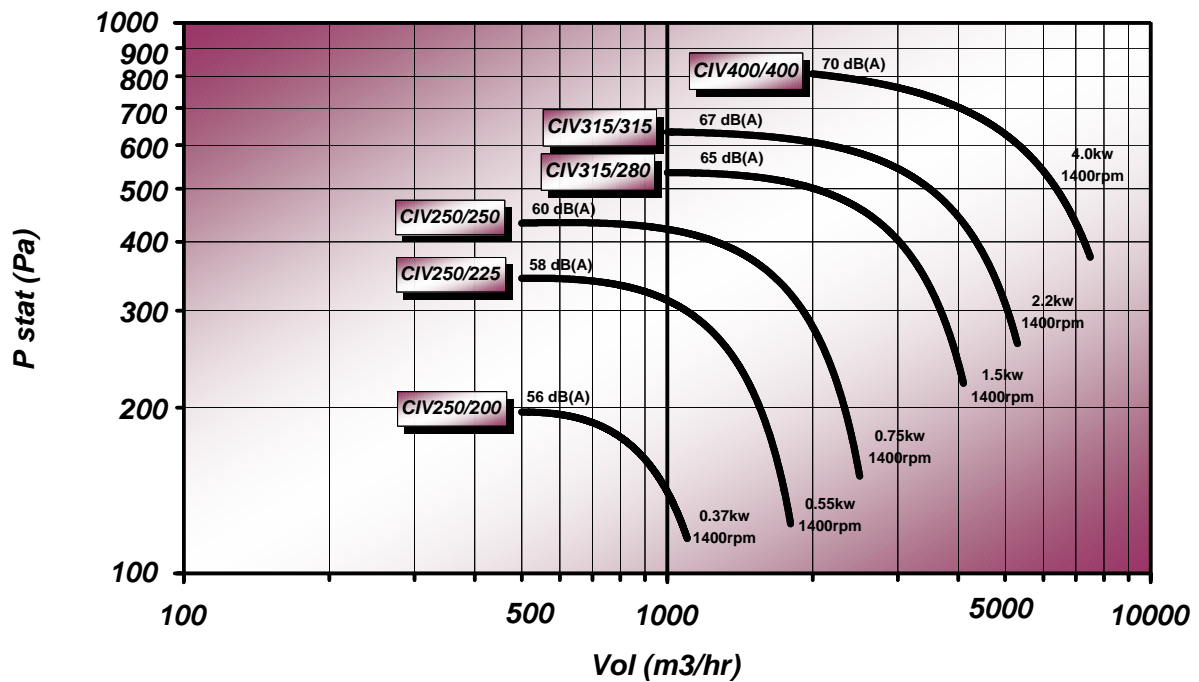

Dimension Chart

Fan Size	A	B	C	D	E	F
CIV250/200	650	325	250	650	8	290
CIV250/225	650	325	250	650	8	290
CIV250/250	650	325	250	650	8	290
CIV315/280	750	400	315	800	12	360
CIV315/315	750	400	315	800	12	360
CIV400/400	950	500	400	1000	16	455